

USER MANUAL

Sit and Stand Desk Assembly Instruction Smart

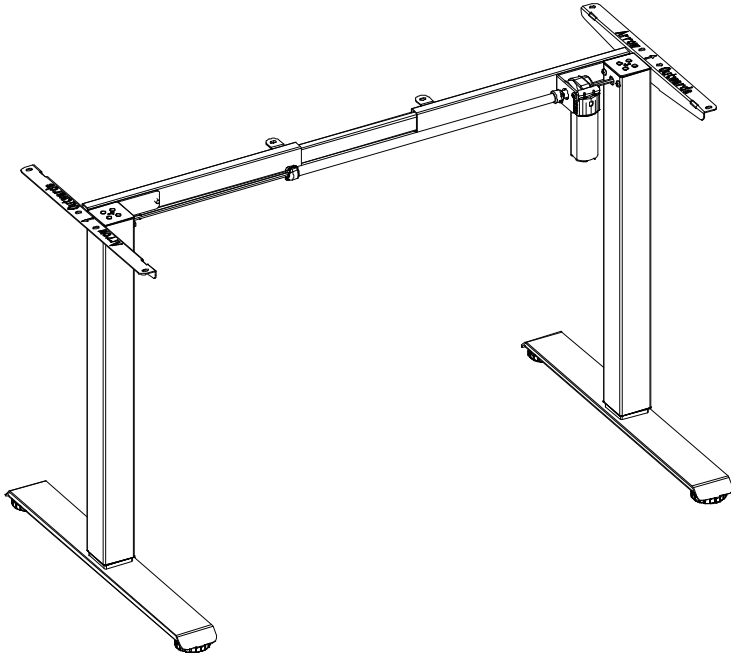

- 3 Height Position Memory
- Vertical Range: 74,5–12,05 cm (including 2.5 cm thick table top)



Power Input
100V-240V



Speed
20 mm/s



Motion Noise
<55dB







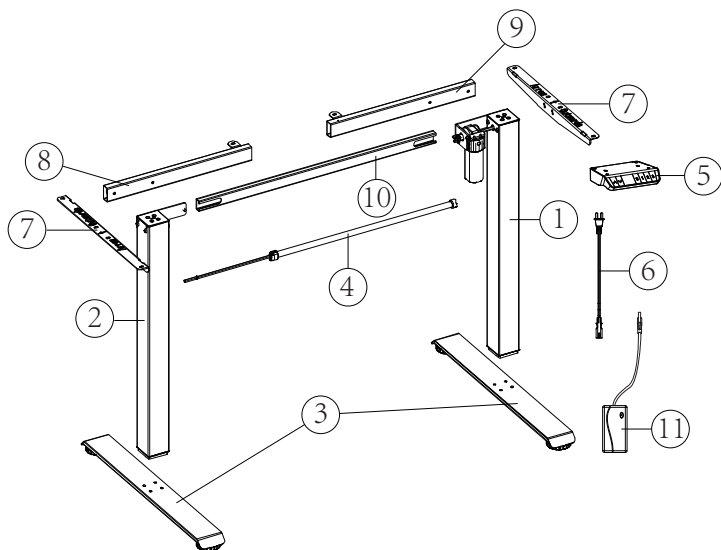

Load Capability
154 lbs / 70 kg

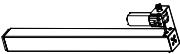
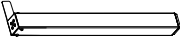
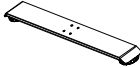
CAUTION: DO NOT EXCEED
MAXIMUM LISTED WEIGHT
CAPACITY.SERIOUS INJURY
OR PROPERTY DAMAGE MAY
OCCUR!

COMPONENT LIST

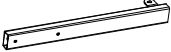

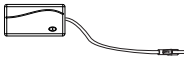
<p>①</p>  <p>Right Table Leg (x1)</p>	<p>②</p>  <p>Left Table Leg (x1)</p>	<p>③</p>  <p>Leg Base (x2)</p>
<p>④</p>  <p>Transmission rod (x1)</p>	<p>⑤</p>  <p>Controller (x1)</p>	<p>⑥</p>  <p>Power cord (x1)</p>
<p>⑦</p>  <p>Side Plate (x2)</p>	<p>⑧</p>  <p>Left Crossbar (x1)</p>	<p>⑨</p>  <p>Right Crossbar (x1)</p>
<p>⑩</p>  <p>Connector (x1)</p>	<p>⑪</p>  <p>Power (x1)</p>	

HARDWARE LIST

A

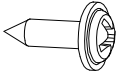

Screws
M5×15mm (x10)

B



Screws
M6×11mm (x12)

C



Screws
M6×35mm (x8)

D

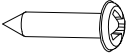

Screws
M3.5×19mm(x2)

E



Allen Key
S=2mm (x1)

F



Allen Key
S=5mm (x1)

G



Cable Clip (x2)

SPARE PARTS



A

M5×15mm (x2)



B

M6×11mm (x2)



C



M6×35mm (x1)



D



M3.5×19mm (x1)

STEP 1

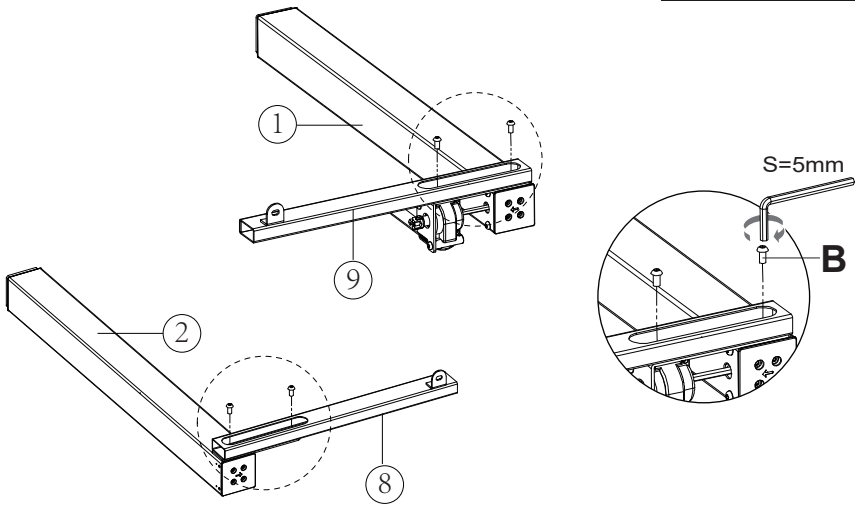
B	 M6×11mm(x4)
F	 S=5mm



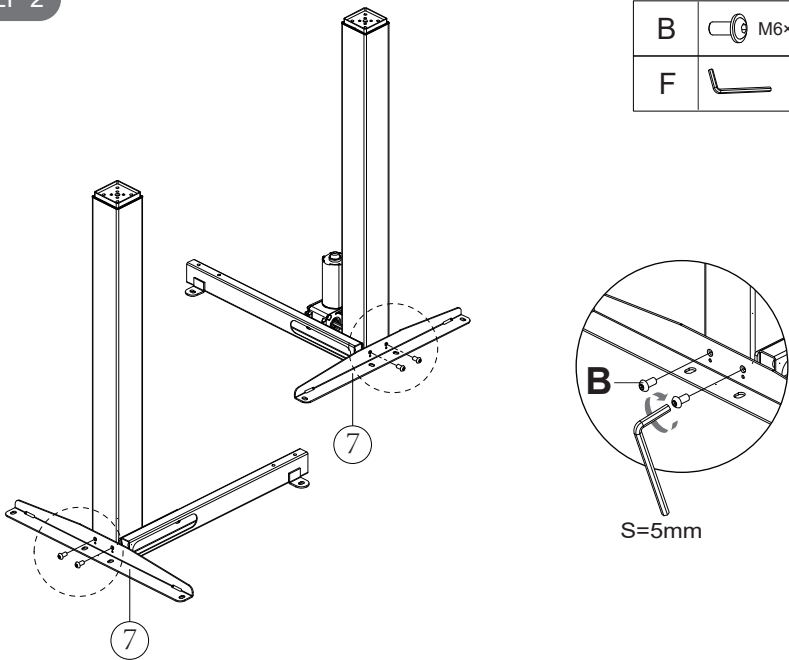

STEP 2

B	 M6×11mm(x4)
F	 S=5mm



STEP 3

C	 M6×35mm(x8)
F	 S=5mm

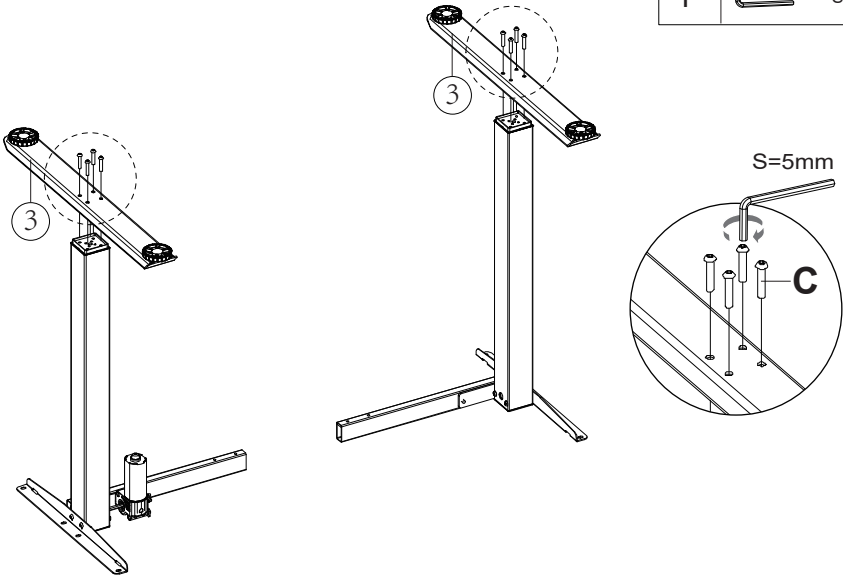

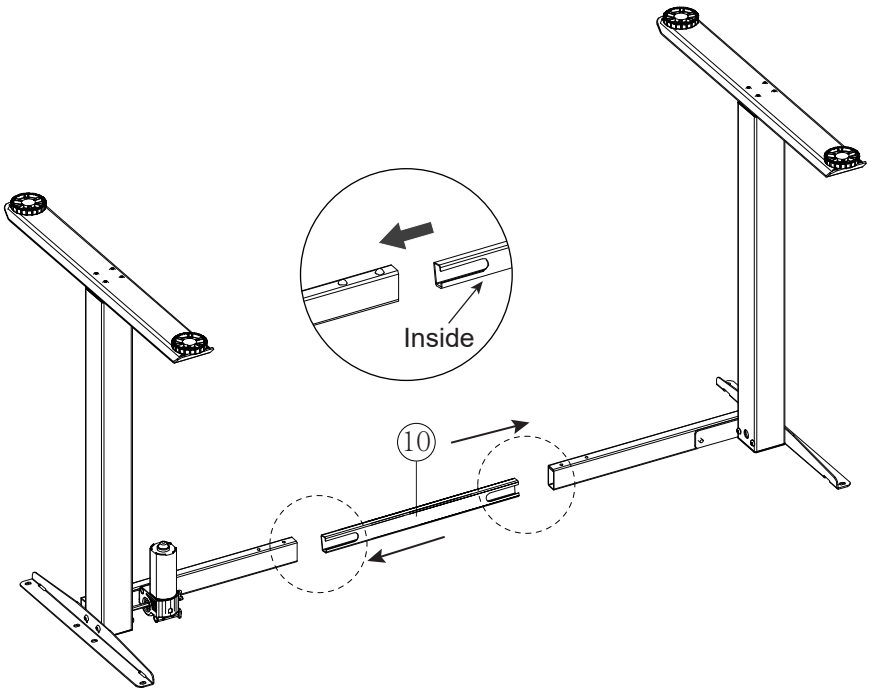

STEP 4

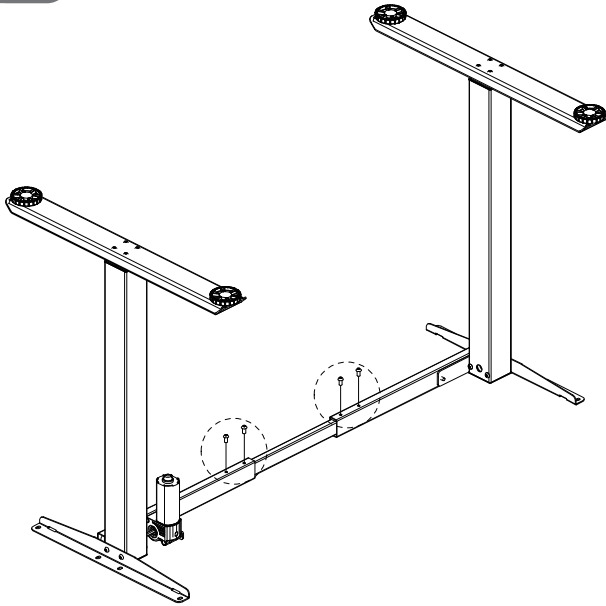

STEP 5



B	 M6×11mm(x4)
F	 S=5mm

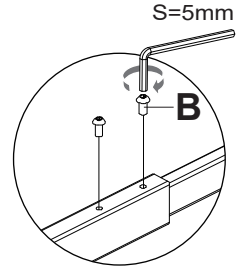

STEP 6

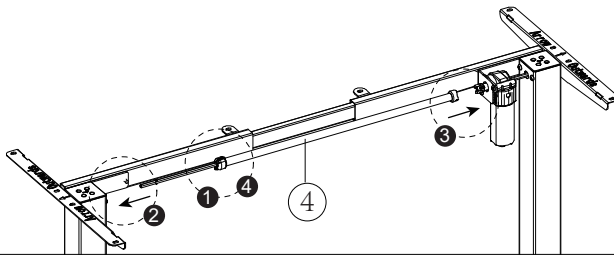

E	 S=2mm
---	---

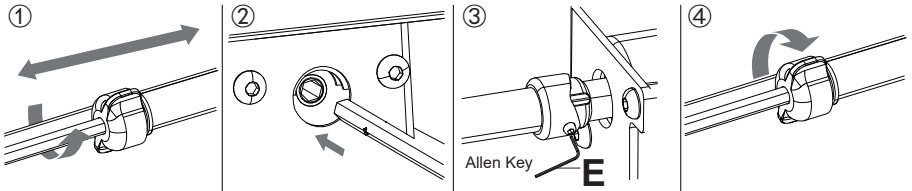

Loosen the knob

Insert the transmission rod into the hex hole and turn the transmission rod clockwise until the left leg goes to the lowest position.

Insert the other end of transmission rod to the slot on the leg (You may rotate the rod slightly for better installation).



Secure the transmission rod to the slot by tightening the pre-assembled set screw using the small Allen key.

Tighten the knob

STEP 7

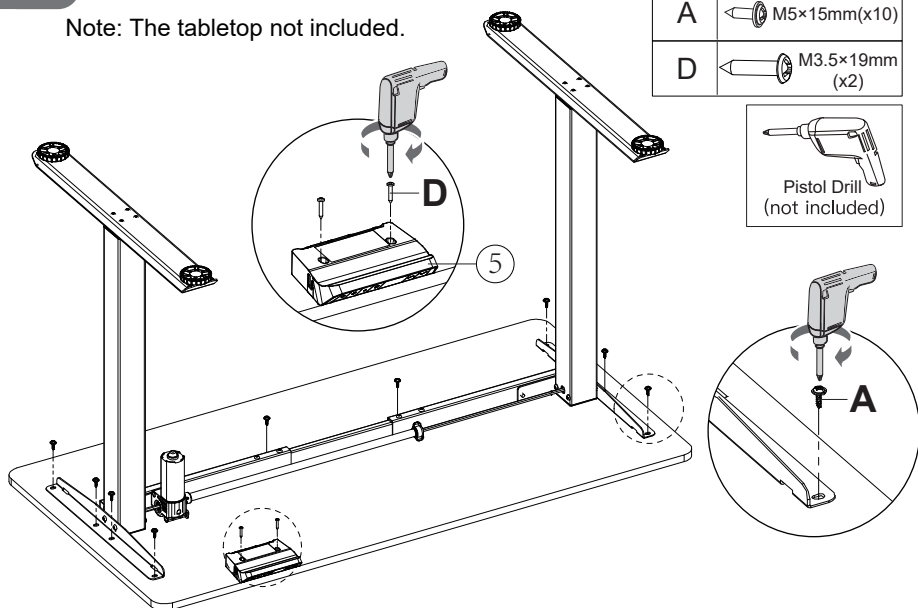
Note: The tabletop not included.



A	 M5×15mm(x10)
D	 M3.5×19mm (x2)

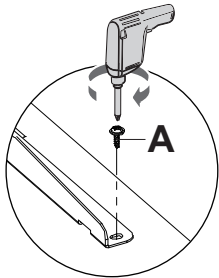

STEP 7

G	 Cable Clip (x2)
---	---

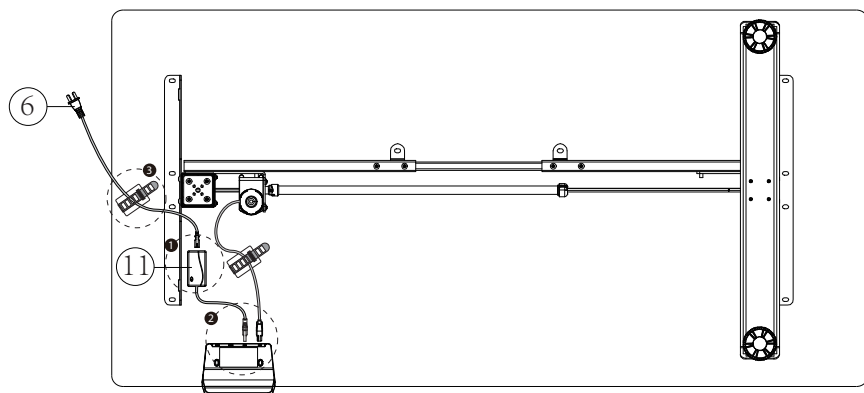

Cable Management

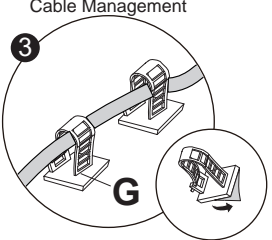
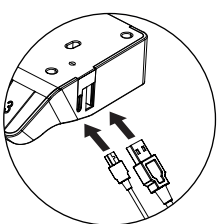
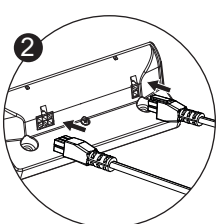
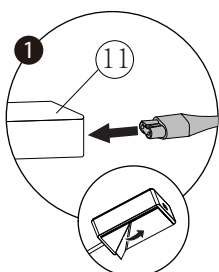

Controller Introduction

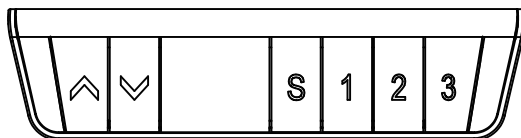

Press the button to raise the desk. Releasing the button stops the process. The maximum height of the desk is 118 cm.



Press the button to lower the desk. Releasing the button stops the process. The minimum height of the desk is 72 cm.



Short press the button, the display flashes, Press any of memory key to save the height.



Memory button: Press the 1 2 3 button and the desk will move to the height that was previously set for the button.

Reset

Press and hold the button for 5 seconds, and the screen will show 'RES.'. Continue holding until the desk goes down to its lowest level and comes back up slightly.

Protection Mode Error Codes

Hot	Overheat protection: When the motor operates continuously, it will stop running to prevent damage caused by overheating. Wait for a period of time (15-20minutes) before making any further height adjustments.
E10	Sensor malfunction warning: Motor safety sensor cannot be detected. Please power off, unplug the cables of the controller, wait for 5 minutes, then plug in the cables and connect the power again, and perform RES settings again.
E20	Overloading Warning: Over the max of loading weight. Power off, take the things off the desk, power back on, and try again.
E02	Operation Status Warning: The desk stops moving if vibration, impact, or incline is detected. If this detection is incorrect, follow the reset instructions before continuing use.
E32	Overvoltage Protection: Input voltage too high. If the correct AC adapter is being used, please power off, unplug the cables of the controller, wait for 5 minutes, then plug in the cables and connect the power again, and perform RES settings again.
E31	Undervoltage Protection: Input voltage too low. If the correct AC adapter is being used, please power off, unplug the cables of the controller, wait for 5 minutes, then plug in the cables and connect the power again, and perform RES settings again.
E60	Unequal Leg Height Warning: Check whether all the legs are at the same height. If necessary, adjust it by following the reset instructions.
Breaking protection	It stops and enters the protection state when motor lines or manual control lines are removed or disconnected accidentally. Returns to normal after reconnected.

Engineering Mode

ChangeDisplayed ↓n	Long press the button, "S--" shows and flashes. Press again and the display shows "Un". Press to select. Press or to switch between 51 "(metric) or 1 n " (imperial). Press to save your choice.
CollisionForce Detection (CF)	Long press the button, "S--" shows and flashes. Press again and the display shows "Un". Press or to switch to "CF". Press to select. Press or to switch between "OFF", Low(L), Normal (n) or Heavy (H) collision force detection. Press to save your choice.
Change Brightness (br)	Long press the button, "S--" shows and flashes. Press again and the display shows "Un". Press or to switch to "br". Press to select. Press or to switch between Low (L), Normal (n) or High (H) brightness. Press to save your choice.